

Datasheet

Field of application and characteristics

The **Ux/14-100k**-system can be used for the optical transmission of 1 to 16 different analog voltage signals outside the ALC or to transmit a stimulus inside the chamber (with optional output filter). It consists of a battery supplied transmitter and an also battery supplied receiver connected to each other with an optical fiber and can also be used to transmit analog signals over long distances or to handle ground potential problems. With the optical transmission, the shielded case and external filter, the system is well equipped for EMI and EME tests.



Application

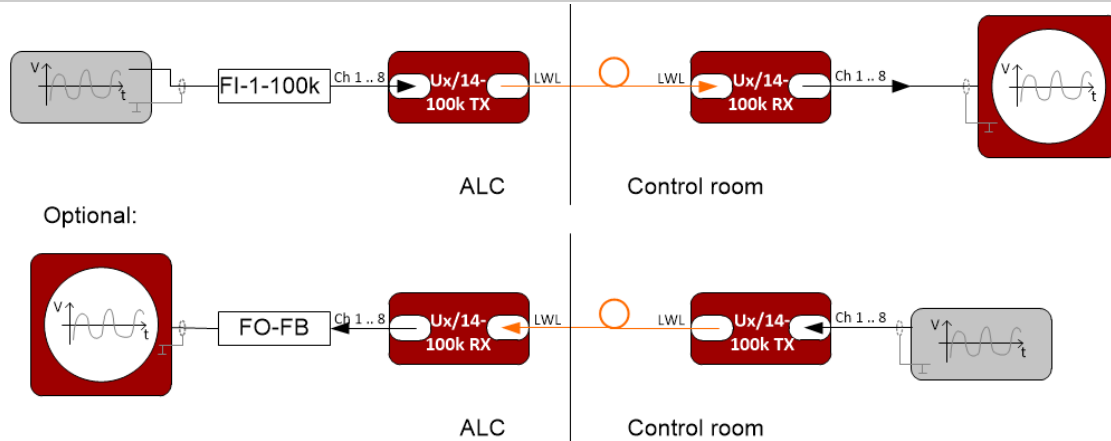

Technical data

Channels:	1 to 16 (SUB-D25) or 1 to 8 (BNC) available
Resolution:	14Bit (min. 10Bit eff.)
Frequency range:	DC ... 100kHz (depending on ext. filter)
Input:	+/-15V
Input impedance:	1MΩ; approx. 10pF
Output:	+/-15V; max. 10mA short circuit protection (short time)
Output impedance:	approx. 10Ω
Sampling rate:	1MS/s at each channel
Power supply:	5 NiMH cells with 4 Ah; > 10h five-poled charge plug
Case dimensions:	120mm x 80mm x 65mm; aluminum case
Weight:	approx. 800g
Misc.:	optional external battery pack / supply available

Optical fiber

Connector / Type: FSMA / simplex-multimode fiber 62,5/125μm

Sales Partner:



ABSOLUTE EMC LLC.
Covering sales in North America
United States, Mexico, & Canada

absolute-emc.com
Phone: 703-774-7505
info@absolute-emc.com