

Shielded Tent

The TBST-200/100/100 shielded tent is designed to suppress interference from ambient noise when carrying out EMC pre-compliance measurements. The TBST-200/100/100 has a size of 200 cm x 100 cm x 100 cm. The tent can accommodate any Tekbox pre-compliance test equipment such as LISNs or TEM-cells.

The shielded tent is composed of two layers of conductive fabrics. It is supported by rigid aluminium profiles. The filter panel at the side provides a 240V/10A mains AC filter, two general purpose 240V/10A AC/DC filters and four coaxial feed through adapters with screw caps. The access opening is sealed with conductive Velcro tape.



Picture 1: shielded tent with closed opening



Picture 2: shielded tent with access opening

Sales Partner:



ABSOLUTE EMC Llc.
Covering sales in North America
United States, Mexico, & Canada

absolute-emc.com
Phone: 703-774-7505
info@absolute-emc.com

Shielded Tent

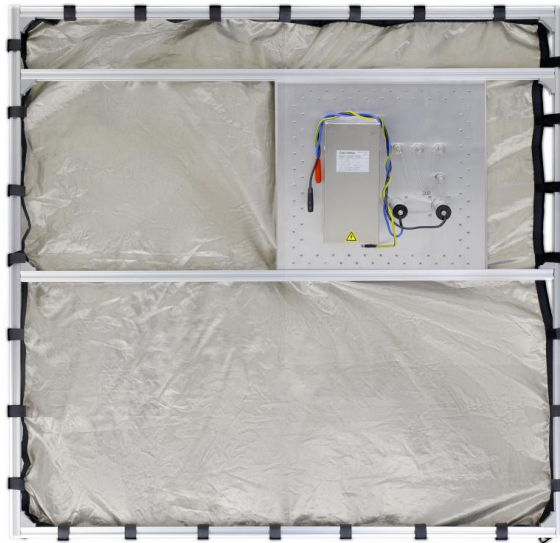

Picture 3: side view with filter panel

1 Warning

Make sure that your set up prevents main phase getting into contact with the metal parts/fabrics of the tent. Always connect protective earth to avoid any hazard of electrical shock.

2 Specification

Outer dimensions:	204 cm x 104 cm x 100 cm
Opening dimensions:	130 cm x 46 cm
Frame:	20 mm x 20 mm extruded aluminium profiles
Shielding:	two layer of conductive silver fabrics
Suspension:	Velcro tape
Filter panel:	1 x 240V / 10A mains AC filter, C19 socket 2 x 240V / 10 A AC/DC filters, attached cables with Banana couplers 3 x N-Female coaxial feed-through connectors with screw caps 1 x BNC-Female coaxial feed-through connector with screw caps
Internal AC-socket:	pigtail cable with detachable female Schuko socket + country specific AC cables with C13 connector
Attenuation:	~50 dB in the range 10 MHz to 6 GHz, see chapter 3
Weight:	17kg + 3kg (packaging)

3 Ambient noise attenuation

Up to 10 MHz: ~30 dB
10 MHz – 6 GHz: ~ 50 dB

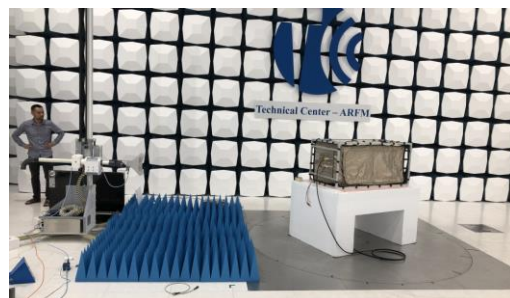

Sales Partner:



ABSOLUTE EMC Llc.
Covering sales in North America
United States, Mexico, & Canada

absolute-emc.com
Phone: 703-774-7505
info@absolute-emc.com

Shielded Tent

3.1 Example: Whip antenna

The ambient noise spectrum plot below was taken with a whip antenna outside of the shielded tent (yellow graph) and inside of the shielded tent (pink graph). The pink graph was taken with lower resolution bandwidth in order to reduce the base noise level of the spectrum analyzer.

The spectrum plots below shows the attenuation of the shielded tent in the range 9 kHz – 1 GHz and in the mobile phone bands.

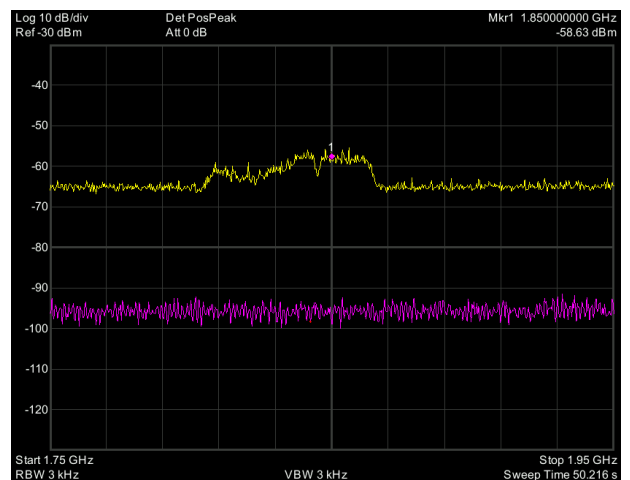
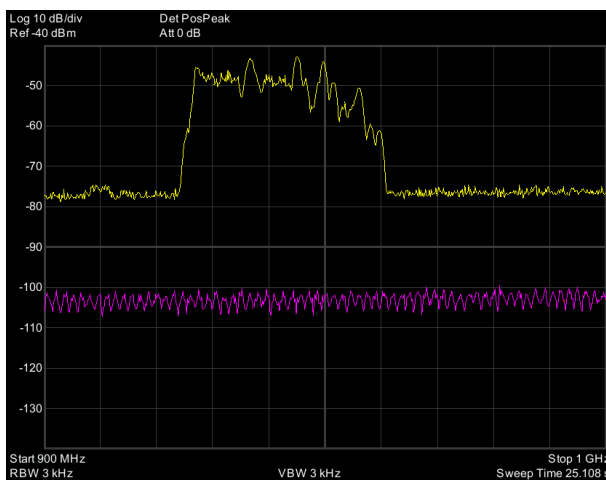
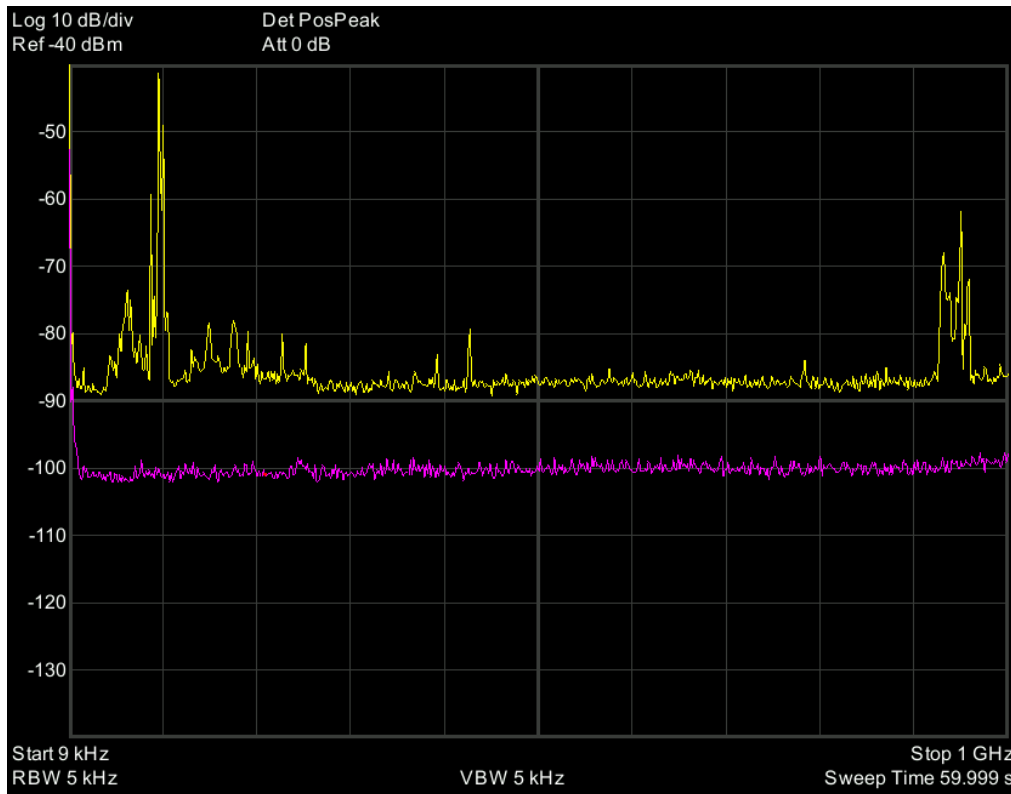

Picture 4: examples, ambient noise outside (yellow) and inside the tent (pink)

Sales Partner:



ABSOLUTE EMC LLC.
Covering sales in North America
United States, Mexico, & Canada

absolute-emc.com
Phone: 703-774-7505
info@absolute-emc.com

Shielded Tent

3.2 Example: Conducted noise measurement

The dark green graph below shows the measured spectrum of a non-powered DUT in a CISPR 25 conducted noise measurement setup. The DUT connects to the TBOH01 5μH LISN with a very short supply cable (10cm). The cable between LISN and DUT and the DUT PCB itself already pick up significant ambient noise from AM and FM broadcast stations.

The light green line shows the results of the same arrangement, with the DUT and LISN placed inside the shielded tent.



Picture 5: CISPR 25 conducted noise measurement; DUT not powered

The graphs below show the conducted noise spectrum of the powered DUT. In the unshielded set up, all emissions, except the first harmonic of the DUT and conducted noise between 40MHz and 50MHz, are hidden under the ambient noise level. An accurate measurement would not be possible without a shielded set up.



Picture 6: CISPR 25 conducted noise measurement; DUT powered

Sales Partner:



ABSOLUTE EMC LLC.
Covering sales in North America
United States, Mexico, & Canada

absolute-emc.com
Phone: 703-774-7505
info@absolute-emc.com

Shielded Tent

4 Assembly

Note that it is not necessary to slide the profile nuts into the profile grooves upfront. The nuts can be positioned and inserted in-line with the grooves. When tightening the nuts, they rotate 90° and lock in a right angle with respect to the direction of the groove.

The tent frame consists of 10 pieces aluminum profiles with 100cm length and 4 pieces aluminum profiles with 200 cm length.

Note that there are two types of screws. The shorter type is used to attach the filter plate to the frame.

Step 1:

Assemble the left side frame which supports the filter plate first. Attach six pieces 100 cm aluminum profiles to each other according to the picture below.

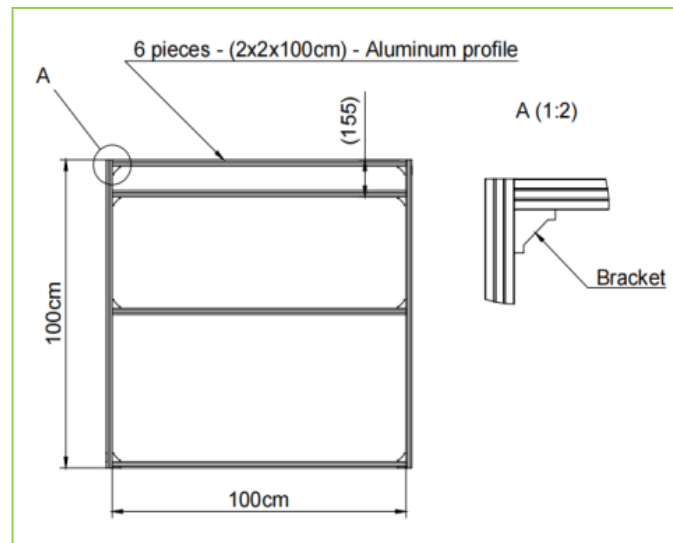

Picture 7: left side frame

Step 2:

Assemble the right-side frame similar as in step 1, using 4 pieces 100 cm) aluminum profiles

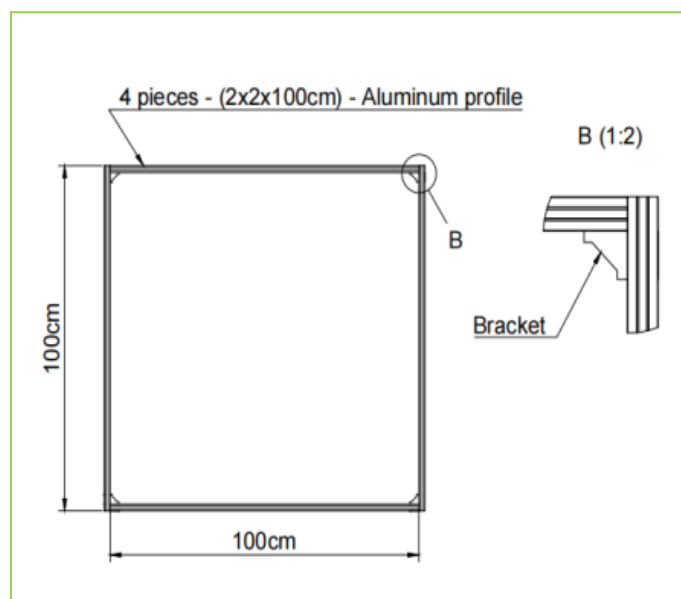

Picture 8: right side frame

Sales Partner:



ABSOLUTE EMC Llc.
Covering sales in North America
United States, Mexico, & Canada

absolute-emc.com
Phone:703-774-7505
info@absolute-emc.com

Shielded Tent

Step 3:

Complete the frame by connecting the two side frames with 4 pieces 120 cm (82 cm) aluminum profiles.

Note that the filter plate is just displayed for reference purpose. The filter plate comes pre-assembled with the tent fabrics and is attached after completion of the frame.

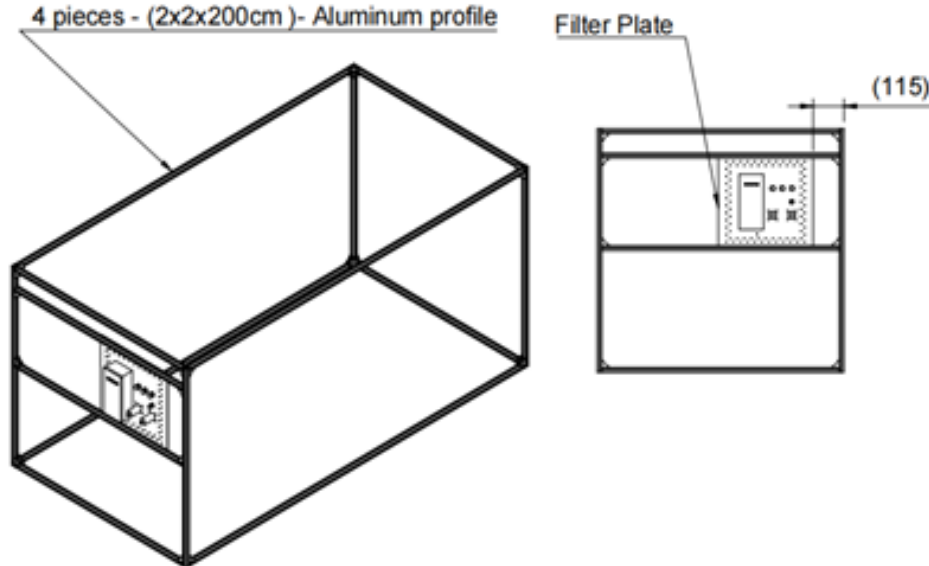

Picture 8: completed frame

Step 4:

Unpack the fabrics and remove the outer foam protection of the filter plate.

Place the frame with the left side at the bottom and support the four corners to get clearance for the filters.

Attach the filter plate with six screws to the frame. Note that the attached fabrics is not displayed in the rendering below

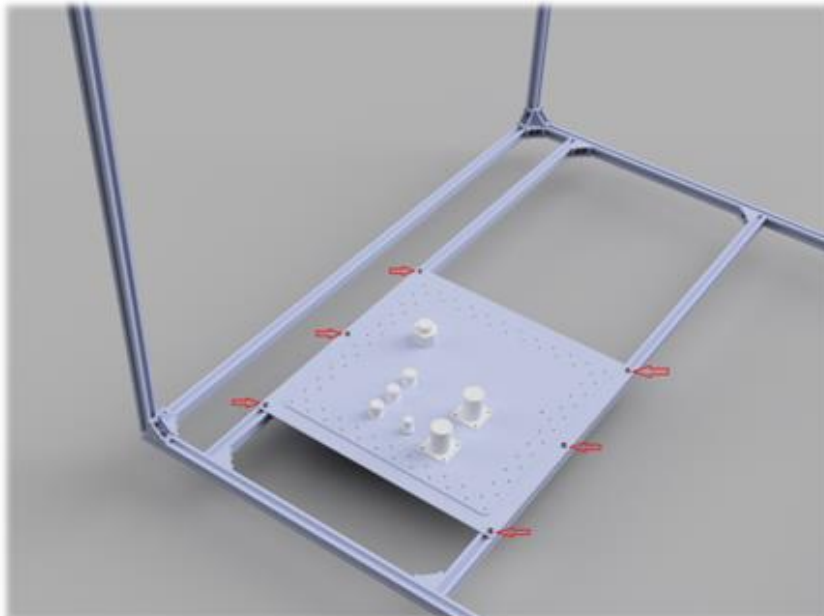

Picture 9: location of the filter plate

Sales Partner:



ABSOLUTE EMC Llc.
Covering sales in North America
United States, Mexico, & Canada

absolute-emc.com
Phone:703-774-7505
info@absolute-emc.com

Shielded Tent

Step 5:

Unfold the fabrics and fasten it to the frame with the attached Velcro strips.



Picture 10: fabrics before attaching it to the frame

5 Hints

Minimize residual ambient noise:

Ensure that there are no gaps between the conductive Velcro hook and loop tapes when closing the access opening. Start closing it at the left or right upper corner and work your way through to the diagonally opposite corner. Then start at the other upper corner and check if you can finalize without any big wave or gap. In case that there is a gap, tear the tapes apart at the respective lower corner and re-attach it until it fits.

Use a RG223 or better cable to connect the spectrum analyzer to the outer connector of the tent. Avoid using RG58 cables, as it may pick up additional ambient noise due to limited shielding of the outer wire mesh.

DUT control:

If your DUT requires connectivity to outside control devices or additional multiple voltages, use shielded control cables and feed it through any unused filter or coaxial connector at the filter panel of the shielded tent. You can also use the AC-filter to feed DC supply voltages into the tent. Similarly, the DC filters are capable of carrying AC. Should you need multiple control cables or a USB or HDMI interface, you can feed it sideways through the Velcro tape: use shielded cables and remove a section of the outer jacket to expose the shielding mesh of the respective cable where it would pass the Velcro tape. Then close the tape tightly, ensuring that the cable shield gets has good electrical contact with the tape. Ensure good ground of the set up and avoid connecting mains phase to GND of the filter panel or surface of the tent.

Sales Partner:



ABSOLUTE EMC LLC.
Covering sales in North America
United States, Mexico, & Canada

absolute-emc.com
Phone: 703-774-7505
info@absolute-emc.com

Shielded Tent

Internal AC mains connector:

The output of the AC filter is connected to a pigtail with detachable (non over molded) female Schuko connector. Use the supplied Schuko/C13 cable or a travel adapter or similar, to match it with any other country specific connector. Alternatively detach the Schuko connector from the pigtail cable and mount a connector that fits your specific requirements.

Protection:

The main body of the tent is made of two layers of conductive fabrics, which may be damaged by sharp tools or sharp edges of equipment. Handle with care.

For additional protection, insert a cardboard, foam or other suitable material at the bottom.

You may also attach MDF or plywood panels to the aluminum frame to protect the bottom or/and to stack equipment on top of the tent.

In case of cuts, patch it with the supplied fabrics remnant. You can stitch it with any thread, provided that stitching establishes a tight contact with the overlapping fabric.

6 Ordering Information

Part Number	Description
TBST-200/100/100-EU	Shielded tent 124 cm x 64 cm x 60 cm, RF cable RG223/N-male to N-male/1.5m, repair patch fabrics, C19 Schuko Power cord
TBST-200/100/100-US	Shielded tent 124 cm x 64 cm x 60 cm, RF cable RG223/N-male to N-male/1.5m, repair patch fabrics, C19 US Power cord, C13 Schuko cable
TBST-200/100/100-UK	Shielded tent 124 cm x 64 cm x 60 cm, RF cable RG223/N-male to N-male/1.5m, repair patch fabrics, C19 UK Power cord, C13 Schuko cable
TBST-200/100/100-AU	Shielded tent 124 cm x 64 cm x 60 cm, RF cable RG223/N-male to N-male/1.5m, repair patch fabrics, C19 Australian Power cord, C13 Schuko cable

7 History

Version	Date	Author	Changes
V 1.0	24.6.2021	Mayerhofer	Creation of the document

Sales Partner:



ABSOLUTE EMC Llc.
Covering sales in North America
United States, Mexico, & Canada

absolute-emc.com
Phone:703-774-7505
info@absolute-emc.com