

TBL5016-2 50 μ H AC-LISN

The TBL5016-2 is a Line Impedance Stabilization Network for the measurement of line-conducted interference within the range of 9kHz to 30MHz, according to the CISPR 16-1-2 standard. The device is designed for testing single phase, AC-powered equipment with supply voltages up to maximum 240V and 16A. Conducted noise can be measured on the phase and on the neutral conductor. The TBL5016-2 is equipped with a switchable limiter/attenuator and an artificial hand connection.

The device is available with country-specific DUT connectors



TBL5016-2 , variant with Schuko connector (CEE 7/3)

Features

- Frequency range: 9 kHz to 30 MHz
- Impedance: 50 Ω || (50 μ H + 5 Ω)
- Artificial hand: 220 pF + 511 Ω
- Switchable PE: 50 Ω || 50 μ H
- Limiter / attenuator: 150 kHz to 30 MHz; 10 dB
- Air core inductors
- Line voltage: max. 240V / 50 – 60 Hz, CAT II
- Max. current: 16A @ 23°C
- DUT socket: country specific
- Measurement connector: 50 Ω BNC
- Power connector: IEC 60320 C19
- Operating Temperature Range: +5°C ... + 40°C; 5% to 80% RH
- Safety: Safety Class I, IEC 1010-01

Application

- EMC conducted noise measurements

Sales Partner:



ABSOLUTE EMC Llc.
Covering sales in North America
United States, Mexico, & Canada

absolute-emc.com
Phone: 703-774-7505
info@absolute-emc.com

TBL5016-2 50μH AC-LISN

Contents

SAFETY	3
1 INTRODUCTION	4
1.1 PRE-COMPLIANCE TESTING OF CONDUCTED EMISSIONS	4
1.2 LINE IMPEDANCE STABILIZATION NETWORKS	4
1.3 RF OUTPUT	5
1.4 INFORMATIVE SCHEMATIC	5
1.5 LABORATORY SET UP	6
1.6 GROUND PLANE	6
2 TBL5016-2 SPECIFICATIONS	7
2.1 CONFORMITY	7
2.2 SAFETY	7
2.3 SPECIFICATIONS	7
2.4 SUPPLY VOLTAGE	7
2.5 FRONT PANEL	8
2.6 REAR PANEL	9
2.7 IMPEDANCE	10
2.8 PHASE	10
2.9 FREQUENCY RESPONSE, S21 FROM DUT PORT TO RF PORT	11
2.10 CALIBRATION DATA ACCORDING TO CISPR 16 -1-2 ANNEX A8	12
2.11 ISOLATION	13
2.12 THERMAL CHARACTERISTICS	14
2.13 PROTECTION	14
2.14 ARTIFICIAL HAND	15
3 OPERATION CHECKLIST	15
4 ORDERING INFORMATION	16
5 HISTORY	16

Tables

<i>Table 1 – Frequency response 9kHz to 30MHz, DUT connector Phase/Neutral to RF connector*</i>	11
<i>Table 2, TBL5016-2 LISN voltage division ratio, calibration data*</i>	13
<i>Table 3– Ordering Information</i>	16
<i>Table 4– History</i>	16

Figures

<i>Figure 1 – Basic AC LISN set up: impedance levels</i>	4
<i>Figure 2 – AC LISN, informative schematic</i>	5
<i>Figure 3 – Conducted noise pre-compliance measurement setup</i>	6
<i>Figure 4 – Front panel layout</i>	8
<i>Figure 5 – DUT connector, pin assignment with reference to the rear power connector *)</i>	8
<i>Figure 6 – Rear panel layout</i>	9
<i>Figure 7 – Mains connector, pin assignment *)</i>	9
<i>Figure 8 – Impedance vs. frequency at DUT terminals*</i>	10
<i>Figure 9– Phase angle vs. frequency at DUT terminals*</i>	10
<i>Figure 10– Frequency response 9kHz to 300MHz, DUT connector Phase/Neutral to RF connector</i>	11
<i>Figure 11 – Calibration set up according to CISPR 16-1-2 Annex A.8.</i>	12
<i>Figure 12 – Voltage Division Ratio versus frequency</i>	12
<i>Figure 13: LISN Isolation, Source to RF out</i>	13
<i>Figure 14: Coil and housing temperature at 16 A DUT current @ 22 °C ambient temperature</i>	14
<i>Figure 15 – Example from CISPR 16, portable electric saw with artificial hand</i>	15

Sales Partner:



ABSOLUTE EMC LLC.
Covering sales in North America
United States, Mexico, & Canada

absolute-emc.com
Phone:703-774-7505
info@absolute-emc.com

TBL5016-2 50 μ H AC-LISN

SAFETY

Operating an AC LISN involves dealing with potentially lethal voltages and high ground leakage currents. The LISN shall only be operated by qualified



Read this manual carefully and be sure to understand the operation of an AC LISN. Make sure that the conducted noise pre – compliance test equipment is set up correctly and that the necessary earth connections are reliably bonded to avoid the risk of lethal electric shocks.

Make sure to understand the operation of the attenuator / limiter to avoid any damage to your test receiver or spectrum analyzer.

Do not carry out any modifications or manipulations of the TBL5016-2. User maintenance of the TBL5016-2 is strictly limited to the replacement of the fuses.

Avoid touching the housing, when operating the LISN at maximum current over extended time. The housing temperature may rise up to 50°C. Turn off the DUT after measurements to avoid unnecessary dissipation.

Sales Partner:



ABSOLUTE EMC Llc.
Covering sales in North America
United States, Mexico, & Canada

absolute-emc.com
Phone:703-774-7505
info@absolute-emc.com

TBL5016-2 50μH AC-LISN

1 Introduction

1.1 Pre-compliance testing of conducted emissions

Full compliance measurement of AC mains supplied products requires a high end set up consisting of an anechoic or screened chamber, a measurement receiver that complies with the requirements of CISPR 16, a 50μH LISN and a suitable table for the measurement setup. Great effort and cost ensures optimum accuracy and repeatability.

Pre-compliance measurements target to give an approximation of the EMC performance of the Device Under Test at a fraction of the cost of full compliance testing. The measurement receiver can be replaced by a spectrum analyzer with suitable sensitivity, bandwidth and detectors. The advent of affordable spectrum analyzers with EMI IF filters and Quasi-Peak detectors made EMC pre-compliance testing affordable for any company which develops electronic products. Together with test accessories from Tekbox, EMC pre-compliance set-ups cost hardly more than a standard oscilloscope a few years ago.

Eliminate uncertainty before going to the test house for compliance testing. There is hardly anything that can give you a return on invest as quickly as EMC pre compliance test equipment.

1.2 Line Impedance Stabilization Networks

Any LISN (line impedance stabilization network) is basically a kind of filter. A LISN is always inserted between the supply input terminals of the DUT (Device Under Test) and the supply which is used to power the DUT. It presents a defined impedance for the noise which is produced by the DUT and emitted via the supply cables of the Device Under Test. The impedance seen by the RF emissions is 50 Ohms || 50μH which results in 50 Ohms for the most part of the specified frequency range. Only at the lower edge of its bandwidth, the impedance decreases. This impedance curve is specified in the corresponding test standards such as CISPR 16-1-2. Having a defined impedance for the emissions at the DUT terminals eliminates any influence of the power source impedance. Consequently, the measured amplitudes of the noise spectrum become independent of the power source characteristics:

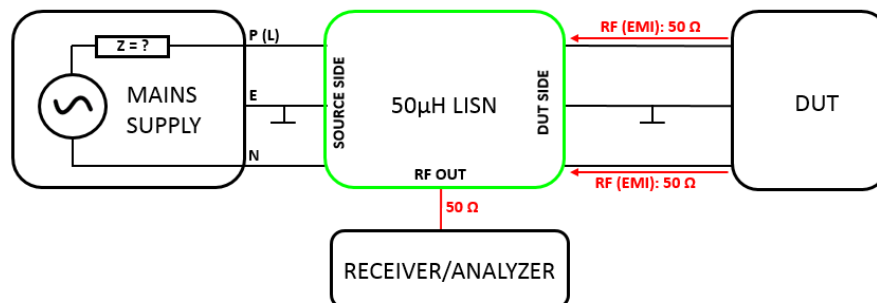

Figure 1 – Basic AC LISN set up: impedance levels

Furthermore, the AC LISN attenuates noise originating from the incoming mains supply towards the Receiver/Analyzer and DUT.

Sales Partner:



ABSOLUTE EMC Llc.
Covering sales in North America
United States, Mexico, & Canada

absolute-emc.com
Phone: 703-774-7505
info@absolute-emc.com

TBL5016-2 50μH AC-LISN

1.3 RF output

The RF output section is AC coupled to either the phase or neutral line. The path can be selected by a rotary switch at the front panel. The RF section also contains an attenuator/limiter and a high pass filter.

Purpose of the high pass filter is the attenuation of harmonics originating from the mains supply. The attenuator/limiter protects the measurement receiver / spectrum analyzer input from high amplitude pulse transients. The phase and neutral line can be the source of such transients, in particular those produced on turning off the DUT. **Consequently it is highly advised to disconnect the spectrum analyzer via cable or line selector switch in OFF position while turning on/off the DUT. Use external attenuators and the built in attenuator/limiter to check the lower frequency range for spurious with high power until you are sure, that the spurious levels are not exceeding the maximum input level range of the spectrum analyzer. For pre-compliance measurements the Attenuator/Limiter should be turned off then, as the limiter is a non-linear component which can create intermodulation and falsify the measurement result. Use external attenuators instead, if necessary**

WARNING: Ensure that the spectrum analyzer RF input is disconnected when powering on or powering off the DUT. Leave the attenuator always turned on, if the DUT switches inductive loads during operation or in case of any uncertainty concerning the DUT characteristics. After ensuring that the spectrum analyzer is not over loaded, turn the Attenuator/Limiter Off or use external attenuators to avoid potential intermodulation products creating a measurement error.

1.4 Informative schematic

The picture below shows the basic topology and the values of the main components of the TBL5016-2 AC LISN. A rotary line selector switch connects the RF output to either Line, Ground or Neutral. A combined 10dB attenuator / 150 kHz highpass filter / limiter can be inserted into the RF path with another rotary switch.

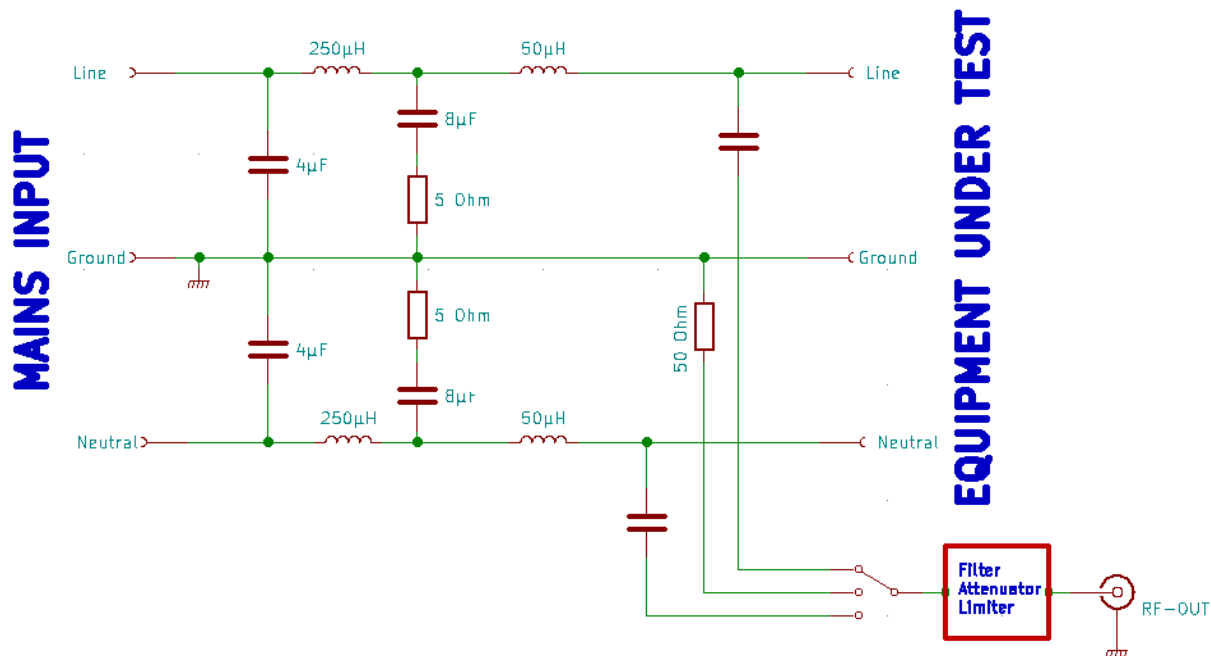

Figure 2 – AC LISN, informative schematic

Sales Partner:



ABSOLUTE EMC Llc.
Covering sales in North America
United States, Mexico, & Canada

absolute-emc.com
Phone: 703-774-7505
info@absolute-emc.com

TBL5016-2 50 μ H AC-LISN

NOTE the high capacitor values, which cause considerable blind current at 50Hz/60Hz line voltages. Direct connection to the mains outlet would cause tripping of the ground fault switch. Refer to the next chapter on how to set up the AC LISN in a standard laboratory environment.

1.5 Laboratory set up

The DUT shall be isolated and elevated from the ground plane. The spectrum analyzer shall measure the conducted emissions on both line and neutral.

The value of the parallel combination of the capacitors is 12 μ F from line and neutral to ground. This causes around 0.75A flowing into the earth connection and would trip the ground fault switch. Hence, an **insulation transformer** is required for any mains supply which is protected by a residual current device or ground fault (earth leakage) circuit breaker and good grounding is essential for safety.

For the exact details of the set up and for the limits of conducted emissions refer to the CISPR 16 and other relevant applicable standards.

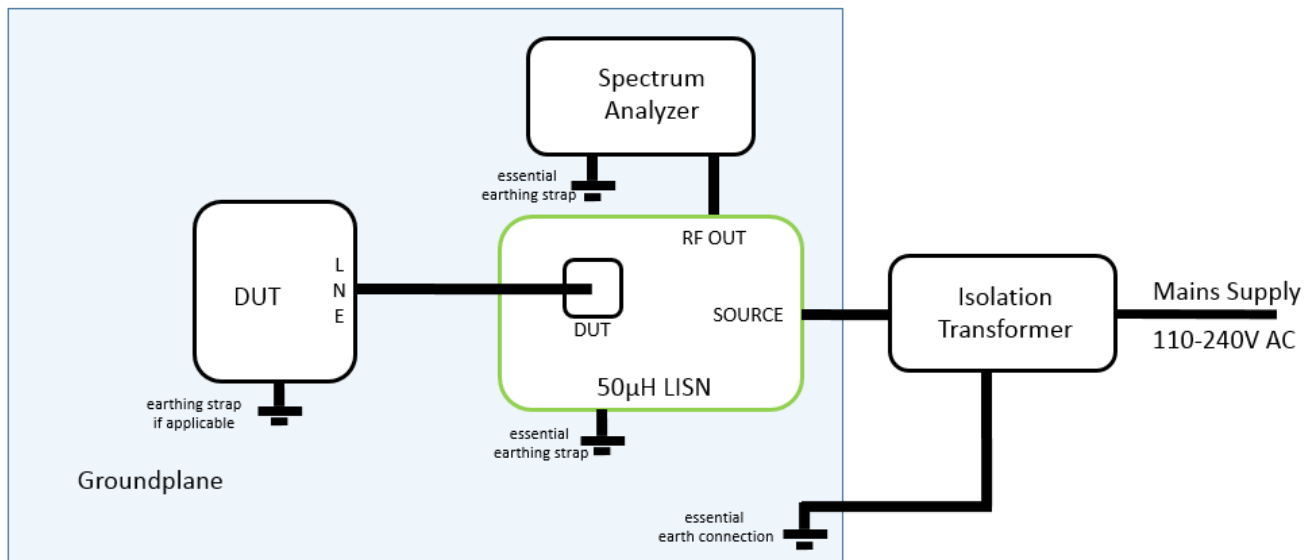

Figure 3 – Conducted noise pre-compliance measurement setup

SAFETY: Ensure that all required earth connections are reliably bonded and that the isolation transformer can supply the required load current.

1.6 Ground plane

Any voltage measurement must be made against a common circuit node which can be referred to as the “zero volt” reference. In order to provide a low impedance zero volt reference for RF measurements, a metal sheet must be provided as ground plane. All ground straps between equipment and ground plane shall be as short as possible and fastened with screws. Exact details on the size of the ground plane and the arrangement of the equipment and interconnecting cables are described in the applicable standards.

In a pre-compliance test set up, as a rule of thumb, the size of the ground plane shall be large enough to accommodate all involved equipment and exceed at least 10cm each side.

Sales Partner:



ABSOLUTE EMC Llc.
Covering sales in North America
United States, Mexico, & Canada

absolute-emc.com
Phone: 703-774-7505
info@absolute-emc.com

TBL5016-2 50 μ H AC-LISN

2 TBL5016-2 specifications

2.1 Conformity

The TBL5016-2 is compliant with Safety Class I according IEC 1010-1.
(EN 61010-1: 1993 / IEC (CEI) 1010-1: 1990 A 1: 1992, EN 61010-1/A2: 1995 / IEC 1010-1/A2: 1995 /)
Rated Pollution degree: 2
Overvoltage category: II
EMC: EN61326-1/A1

2.2 Safety

In order to ensure safe operations, the user must follow all safety relevant information of this manual. All housing parts are connected with the earth conductor of the power cable, DUT socket, yellow banana receptacle and with the ground angles at the front and rear panel of the housing. It is not allowed to carry out any modifications or manipulations of the TBL5016-2. The TBL5016-2 shall be operated by qualified laboratory staff only.

2.3 Specifications

- Frequency range: 9 kHz to 30 MHz
- Impedance: 50 Ω || (50 μ H + 5 Ω)
- Artificial hand: 220 pF + 511 Ω
- Switchable PE: 50 Ω || 50 μ H
- Limiter / attenuator: 150 kHz to 30 MHz; 10 dB
- Line voltage: max. 240V / 50 – 60 Hz, CAT II
- Max. current: 16A @ 23°C; Fuses: 16A, slow
- DUT socket: country specific, **note country specific DUT socket limits (see chapter 4)**
- Measurement connector: 50 Ω BNC
- Power connector: IEC 60320 C19
- Operating Temperature Range:
- +5°C ... + 40°C; 5% to 80% RH
- Safety: Safety Class I, IEC 1010-01

2.4 Supply voltage

The TBL5016-2 does not require any particular voltage settings. It can be operated with any supply voltage which does not exceed 240V, 50Hz/60Hz.

Sales Partner:



ABSOLUTE EMC Llc.
Covering sales in North America
United States, Mexico, & Canada

absolute-emc.com
Phone:703-774-7505
info@absolute-emc.com

TBL5016-2 50 μ H AC-LISN

2.5 Front Panel

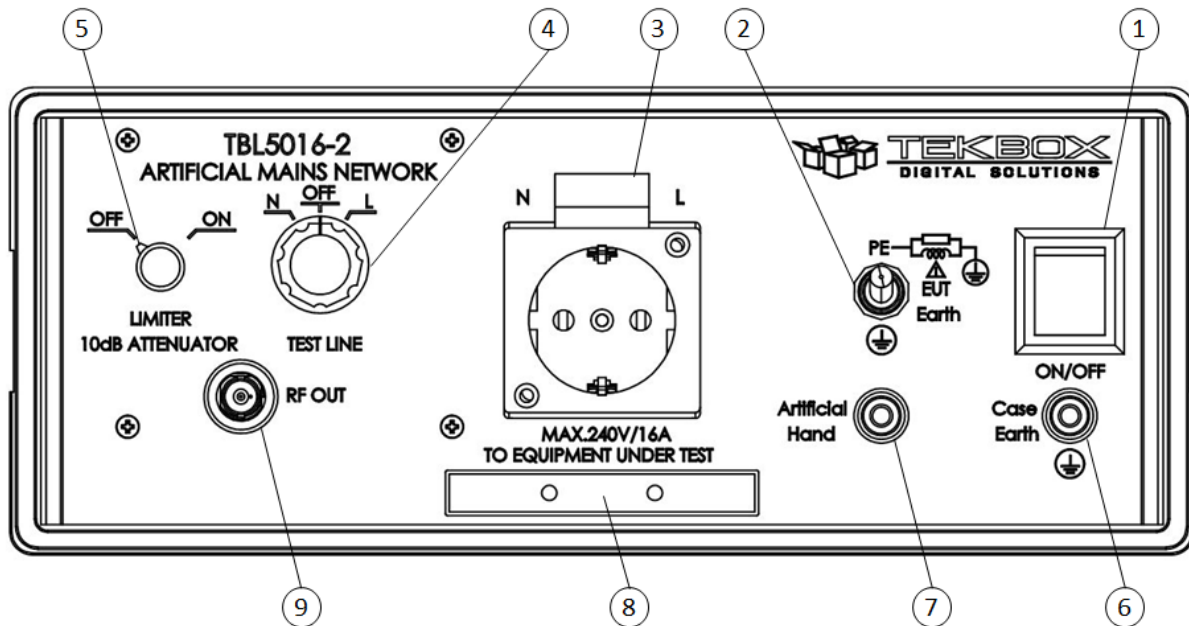

Figure 4 – Front panel layout

- 1) Mains switch
- 2) Protective Earth switch to connect DUT earth either directly to case earth, or via 50 μ H || 50 Ohm
- 3) DUT socket, country specific
- 4) RF path selection, N (neutral), OFF, L (phase)
- 5) Limiter + 10 dB attenuator + 150kHz high pass filter switch
- 6) Auxiliary case earth connector, safety banana jack
- 7) Artificial hand connector, safety banana jack
- 8) Ground plane bracket
- 9) 50 Ω RF output, BNC jack

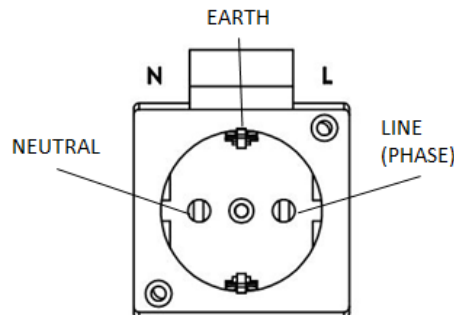

Figure 5 – DUT connector, pin assignment with reference to the rear power connector *)

*) Provided that the TBL5016-2 is correctly connected to the mains power outlet

Sales Partner:



ABSOLUTE EMC Llc.
Covering sales in North America
United States, Mexico, & Canada

absolute-emc.com
Phone: 703-774-7505
info@absolute-emc.com

TBL5016-2 50µH AC-LISN

2.6 Rear Panel

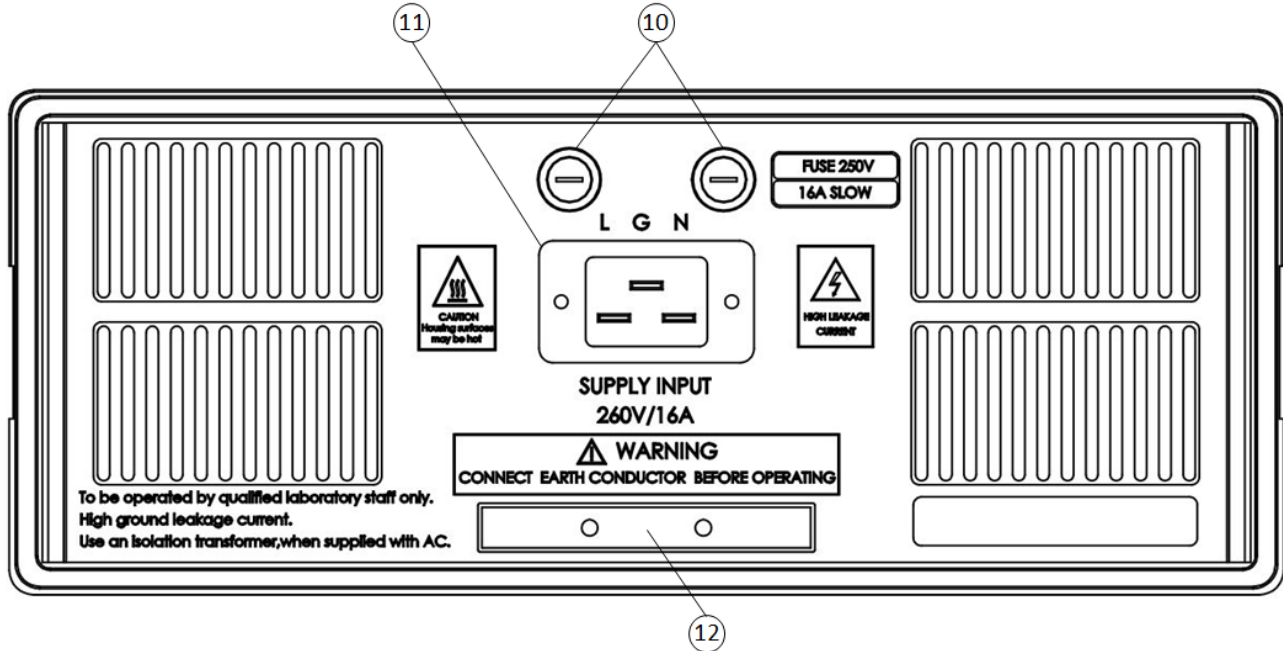

Figure 6 – Rear panel layout

- 10) Power socket: IEC 60320 C19
- 11) Fuses, 16A, slow
- 12) Ground plane bracket

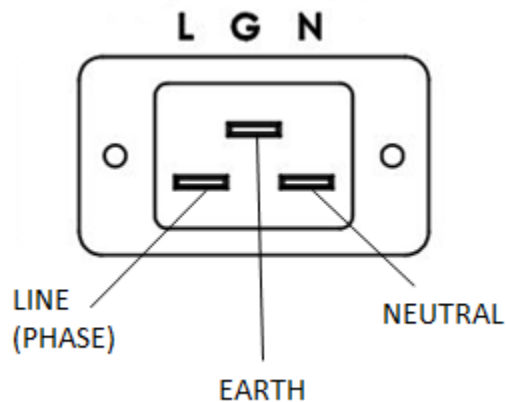

Figure 7 – Mains connector, pin assignment *)

*) Requires correct connection of the TBL5016-2 to the mains power outlet (-> Schuko orientation)

Sales Partner:



ABSOLUTE EMC Llc.
Covering sales in North America
United States, Mexico, & Canada

absolute-emc.com
Phone: 703-774-7505
info@absolute-emc.com

TBL5016-2 50 μ H AC-LISN

2.7 Impedance

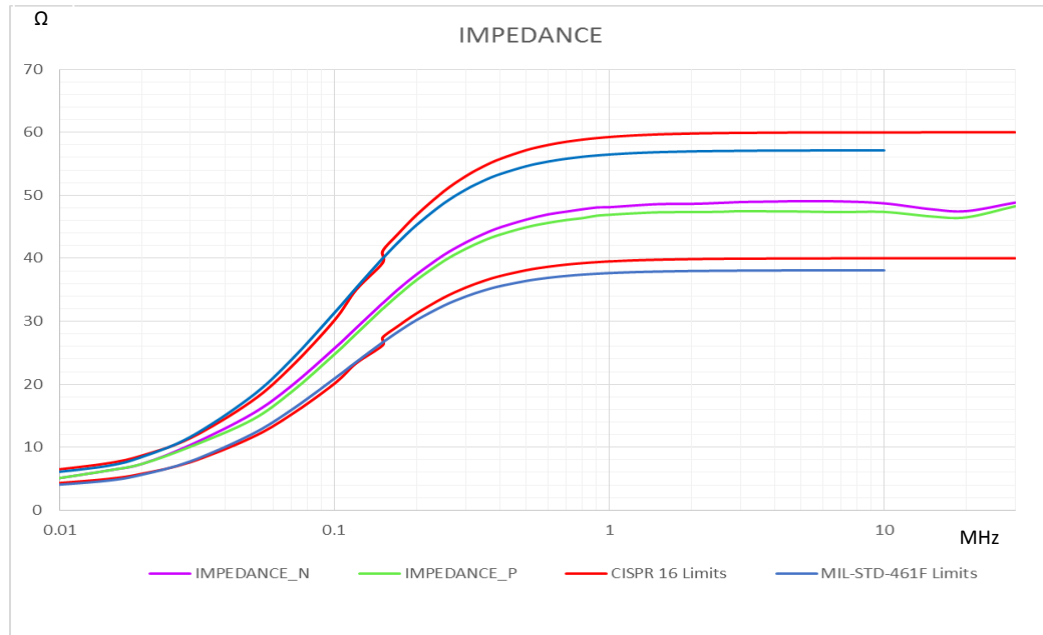

Figure 8 – Impedance vs. frequency at DUT terminals*

*) Impedance measured at PCB edge. The wiring from DUT connector to the PCB can be considered as an additional 11 cm of DUT supply cable length.

2.8 Phase

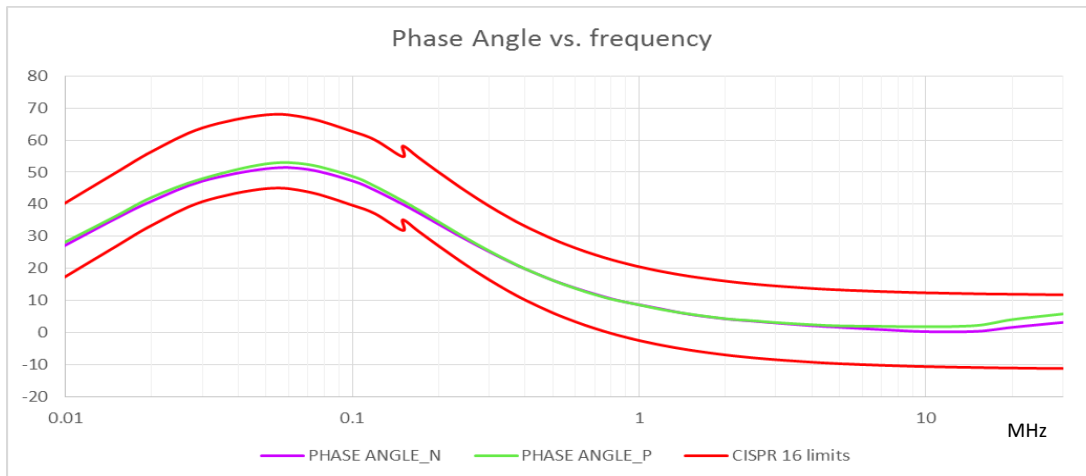

Figure 9– Phase angle vs. frequency at DUT terminals*

*) Phase angle measured at PCB edge. The wiring from DUT connector to the PCB can be considered as an additional 11 cm of DUT supply cable length

Sales Partner:



ABSOLUTE EMC Llc.
Covering sales in North America
United States, Mexico, & Canada

absolute-emc.com
Phone: 703-774-7505
info@absolute-emc.com

TBL5016-2 50µH AC-LISN

2.9 Frequency response, S21 from DUT port to RF port

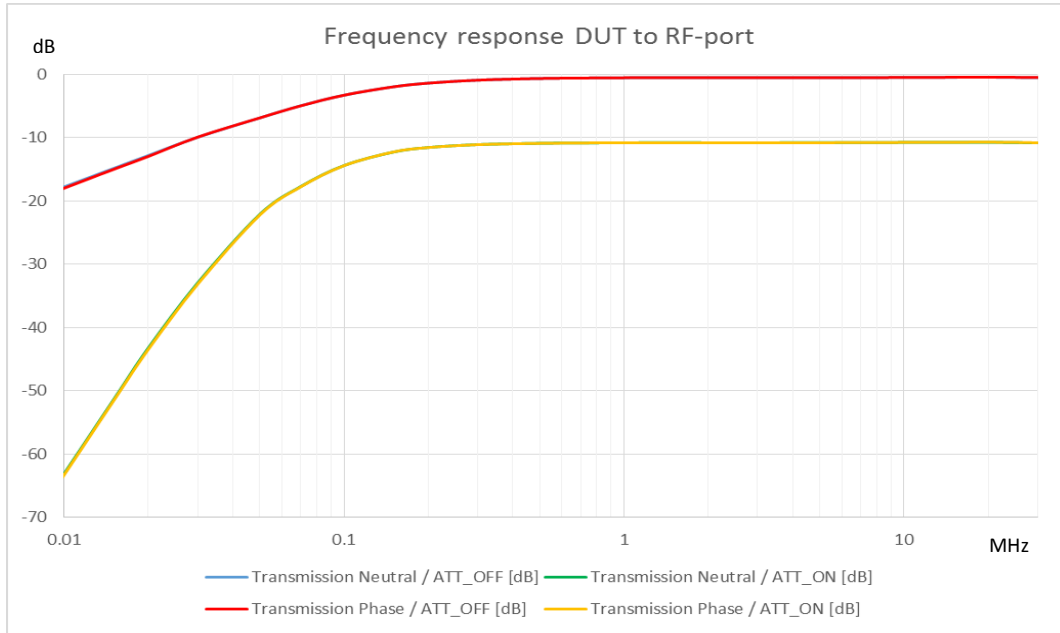

Figure 10– Frequency response 9kHz to 300MHz, DUT connector Phase/Neutral to RF connector

Frequency [MHz]	Transmission Neutral / ATT_OFF [dB]	Transmission Neutral / ATT_ON [dB]	Transmission Phase / ATT_OFF [dB]	Transmission Phase / ATT_ON [dB]
0.009	-18.53	-66.12	-18.74	-66.31
0.015	-14.87	-51.43	-15.01	-51.59
0.02	-12.81	-43.21	-12.95	-43.42
0.03	-9.93	-32.95	-9.91	-33.14
0.05	-6.87	-22.12	-6.87	-22.21
0.07	-4.95	-17.72	-4.97	-17.76
0.1	-3.28	-14.39	-3.28	-14.41
0.15	-1.96	-12.27	-1.96	-12.26
0.2	-1.37	-11.55	-1.38	-11.55
0.3	-0.91	-11.09	-0.91	-11.1
0.5	-0.65	-10.88	-0.65	-10.89
0.75	-0.57	-10.83	-0.57	-10.82
1	-0.54	-10.81	-0.53	-10.8
1.25	-0.52	-10.78	-0.52	-10.79
2.5	-0.52	-10.79	-0.52	-10.81
5	-0.51	-10.78	-0.51	-10.79
7.5	-0.51	-10.77	-0.51	-10.78
10	-0.49	-10.75	-0.49	-10.75
20	-0.46	-10.73	-0.44	-10.71
30	-0.52	-10.82	-0.49	-10.79

Table 1 – Frequency response 9kHz to 30MHz, DUT connector Phase/Neutral to RF connector*

*) measured from PCB edge (RF board terminals) to BNC

Sales Partner:



ABSOLUTE EMC Llc.
Covering sales in North America
United States, Mexico, & Canada

absolute-emc.com
Phone: 703-774-7505
info@absolute-emc.com

TBL5016-2 50μH AC-LISN

2.10 Calibration data according to CISPR 16 -1-2 Annex A8

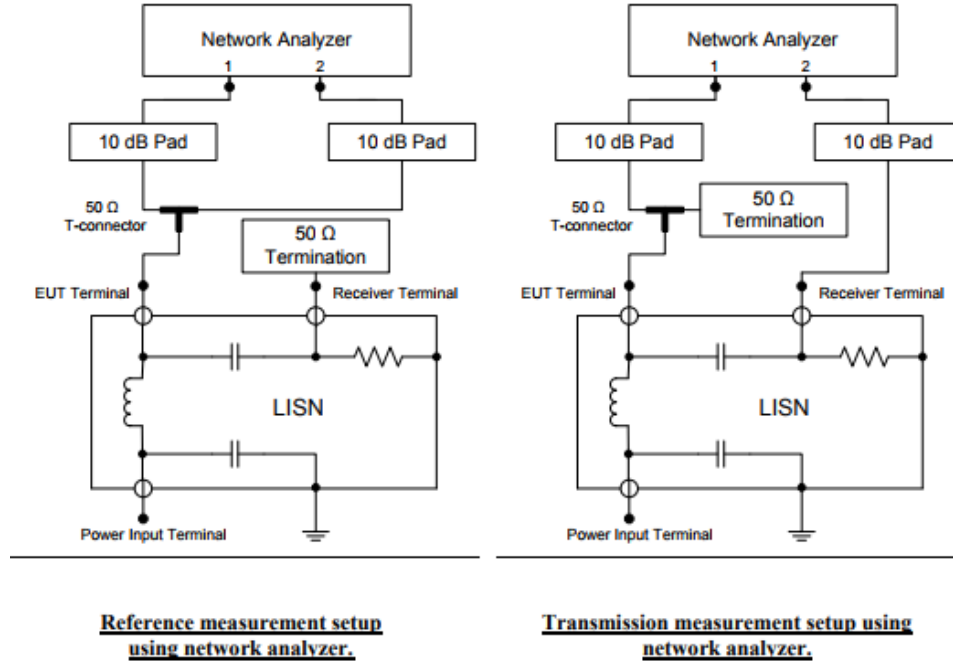

Figure 11 – Calibration set up according to CISPR 16-1-2 Annex A.8.

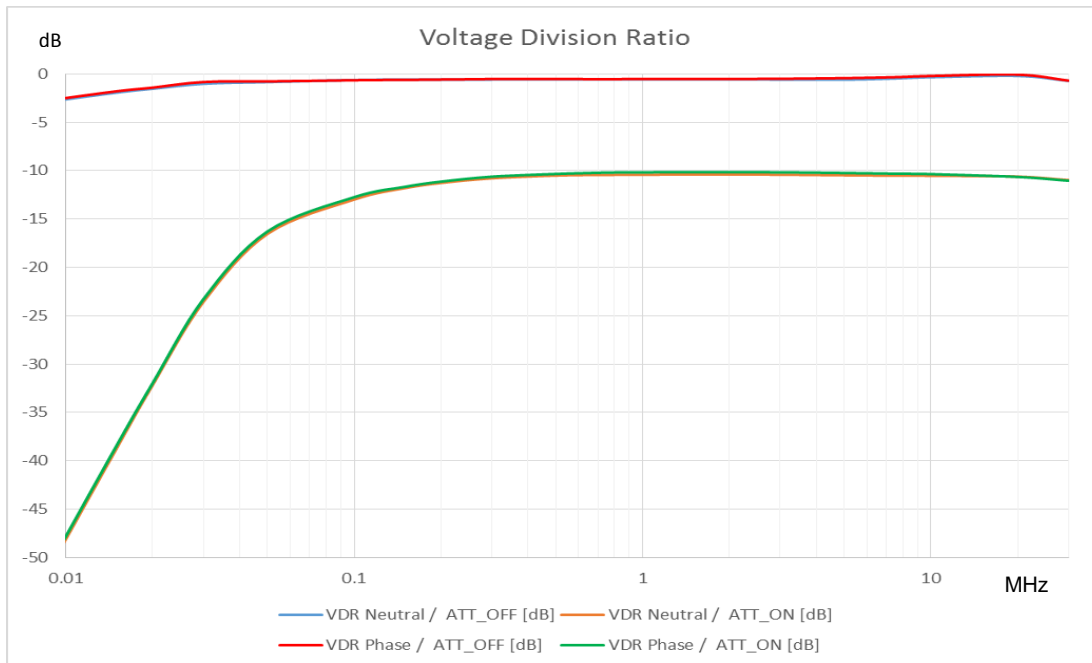

Figure 12 – Voltage Division Ratio versus frequency

Sales Partner:



ABSOLUTE EMC Llc.
Covering sales in North America
United States, Mexico, & Canada

absolute-emc.com
Phone: 703-774-7505
info@absolute-emc.com

TBL5016-2 50μH AC-LISN

Frequency[MHz]	VDR Neutral / ATT_OFF [dB]	VDR Neutral / ATT_ON [dB]	VDR Phase / ATT_OFF [dB]	VDR Phase / ATT_ON [dB]
0.009	-2.81	-50.54	-2.67	-50.25
0.015	-1.93	-38.69	-1.79	-38.42
0.02	-1.53	-32.15	-1.41	-31.97
0.03	-1.02	-23.55	-0.83	-23.29
0.05	-0.84	-16.53	-0.77	-16.29
0.1	-0.63	-12.98	-0.65	-12.74
0.15	-0.59	-11.8	-0.61	-11.67
0.2	-0.59	-11.27	-0.58	-11.13
0.3	-0.58	-10.79	-0.53	-10.62
0.5	-0.57	-10.51	-0.53	-10.34
0.75	-0.57	-10.44	-0.54	-10.2
1	-0.56	-10.42	-0.53	-10.17
2.5	-0.58	-10.41	-0.51	-10.16
5	-0.59	-10.48	-0.43	-10.24
7.5	-0.47	-10.52	-0.33	-10.31
10	-0.34	-10.53	-0.21	-10.36
20	-0.21	-10.62	-0.07	-10.65
30	-0.71	-10.97	-0.69	-11.04

Table 2, TBL5016-2 LISN voltage division ratio, calibration data*

*) measured from PCB edge (RF board terminals) to BNC

2.11 Isolation

Limit according
CISPR 16-1-2

Neutral
Phase

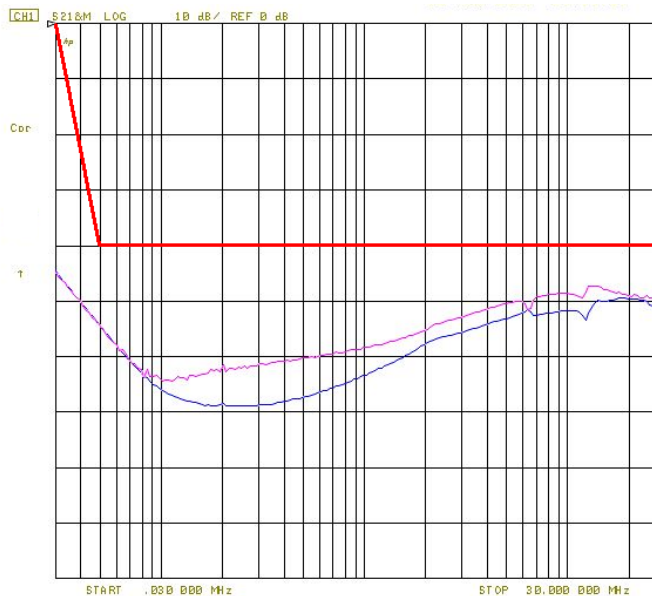

Figure 13: LISN Isolation, Source to RF out

The isolation is measured between the mains (source) connector and RF port, with the DUT port terminated with 50 Ohm.

Sales Partner:



ABSOLUTE EMC LLC.
Covering sales in North America
United States, Mexico, & Canada

absolute-emc.com
Phone: 703-774-7505
info@absolute-emc.com

TBL5016-2 50µH AC-LISN

2.12 Thermal characteristics

Avoid touching the housing, when operating the LISN at maximum current over extended time. Typical conducted noise measurements take less than 10 minutes per line. Turn off the DUT after measurements to avoid unnecessary dissipation.

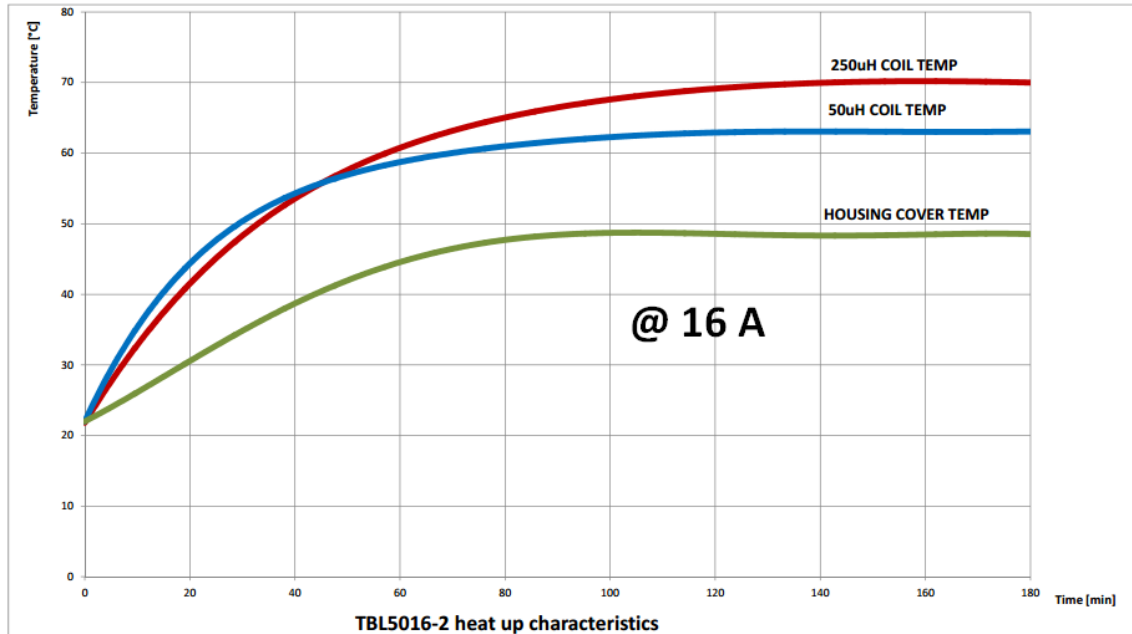

Figure 14: Coil and housing temperature at 16 A DUT current @ 22 °C ambient temperature

2.13 Protection

The TBL5016-2 offers several levels of protection to prevent surges appearing at the input of the measurement receiver or analyzer.

Both the neutral line and phase line are equipped with a 275V varistor to ground. The RF path is always protected by a 50V gas discharge tube.

When the attenuator/limiter switch is in "ON" position, a 10dB attenuator and a Schottky diode limiter offer additional protection. Furthermore, the attenuator/limiter path contains a 150kHz high pass filter.

Sales Partner:



ABSOLUTE EMC LLC.
Covering sales in North America
United States, Mexico, & Canada

absolute-emc.com
Phone: 703-774-7505
info@absolute-emc.com

TBL5016-2 50 μ H AC-LISN

2.14 Artificial hand

When performing conducted noise measurements with devices which are held in hand, the artificial hand network mimics the influence of the human hand. Examples for such devices are power tools, hair driers, kitchen tools and similar equipment.

Insulated housing sections that are touched by the hand when operating the equipment are covered with metal foil and connected to the artificial hand jack.

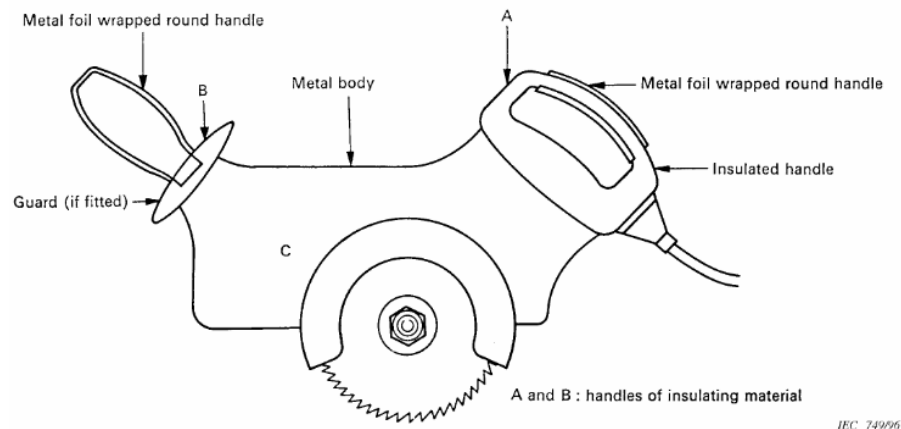

Figure 15 – Example from CISPR 16, portable electric saw with artificial hand

3 Operation checklist

- Setup the isolation transformer, TBL5016-2, DUT and spectrum analyzer according to Figure 3.
- Before powering the isolation transformer, measure the connectivity between each equipment chassis and ground plane.
- Ensure that the supply cable of the isolation transformer, the supply cable of the LISN, the supply cable of the spectrum analyzer and if applicable the supply cable of the DUT contain a ground conductor.
- Ensure that the line selection switch of the TBL5016-2 is set to “OFF”.
- Ensure that the Protective Earth switch is set to direct ground position
- Ensure that the Limiter/Attenuator switch of the TBL5016-2 is in “ON” position.
- Ensure that the power switch of the TBL5016-2 is in “OFF” position.
- Ensure that the DUT power switch is in “OFF” position.
- Power on the isolation transformer
- Power on the spectrum analyzer, set frequency, bandwidth, amplitude etc.
- Power on the TBL5016-2
- Power on the DUT
- Set the line selection switch to “L” or “N” to carry out the conducted noise measurements. Disengage the Limiter/Attenuator for better sensitivity and in order to avoid potential intermodulation.

Sales Partner:



ABSOLUTE EMC Llc.
Covering sales in North America
United States, Mexico, & Canada

absolute-emc.com
Phone: 703-774-7505
info@absolute-emc.com

TBL5016-2 50μH AC-LISN

- After finishing the measurement, proceed in reverse order. Take special care to set the limiter/attenuator to “ON” and the line selection switch to “OFF” before powering off the DUT.

4 Ordering Information

Part Number	Description
TBL5016-2 -EU	50μH LISN with Schuko socket (CE7/3, 16A), 16A cold appliance cable, 75 cm coaxial cable BNC-male / N-male
TBL5016-2 -US	50μH LISN with US socket (NEMA 5-15, grounded, type B, 15A), 15A cold appliance cable, 75 cm coaxial cable BNC-male / N-male
TBL5016-2 -AU	50μH LISN with Australian socket (AS/NZS 3112:201, 15A), 15A cold appliance cable, 75 cm coaxial cable BNC-male / N-male
TBL5016-2 -GB	50μH LISN with English socket (BS1363, 13A), 16A cold appliance cable, 75 cm coaxial cable BNC-male / N-male
TBL5016-2 -xx	Any other socket requirements upon customer request will have 2-3 weeks lead time
TBSP-16-Schuko	Rewirable 16A Schuko (CEE 7/4) plug for extension cables
TBLCAC-16-Schuko	Additional cold appliance cable, 16A, 1.8m, CE7/4 to C20

Table 3– Ordering Information

Note the maximum current limitations of country specific DUT sockets and cold appliance cables. If you want to make full use of the 16A maximum current rating, order a TBL5016-2-EU plus a rewirable Schuko plug which can be used to make a 16A extension cable for the DUT.

5 History

Version	Date	Author	Changes
V1.0	18.06.2020	Mayerhofer	Creation of the document
V1.1	7.9.2020	Mayerhofer	Information on country specific DUT connectors added, version number corrected

Table 4– History

Sales Partner:



ABSOLUTE EMC Llc.
Covering sales in North America
United States, Mexico, & Canada

absolute-emc.com
Phone:703-774-7505
info@absolute-emc.com