

CAR-PFS- RCal-KIT

Calibration kit for CAR-PFS according to standard

Highlights:

- Low inductive, high precision lead resistors
- Load resistors for power line and data line
- Software procedure for verification



According to

LV 124

LV 148

VW 80000

General:

The CAR-PFS-RCal Kit includes four load resistors for verification of pulses E10 and E13 of LV124 of the CAR-PFS80. There, power lines and data lines can get verified.

The two load resistances 1Ω and 100Ω can directly plugged into the device for verification of the power lines in LV124 and LV148.

The box with the 1Ω and 1kΩ resistance is for verification of data lines in LV 124.

Corresponding verification procedures are predefined in the setup menu of the Car-PFS80.

Sales Partner:



ABSOLUTE EMC LLC.
Covering sales in North America
United States, Mexico, & Canada

absolute-emc.com
Phone: 703-774-7505
info@absolute-emc.com

Page 1 of 3
www.hilo-test.de

Operation:

Power Lines:

This point applies to LV 124 (E10). The LV 124 requires reference measurements to prove the slew rate. For reference measurement, a 1Ω and a 100Ω ($\pm 5\%$) resistor (low inductance) are connected to the output.

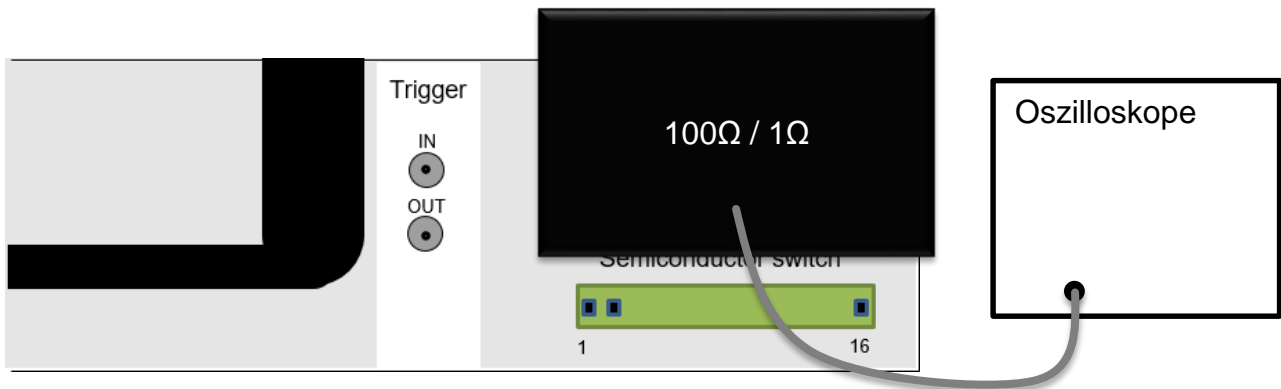

The CAR-PFS-R-CAL Kit avoids, with its short connections, additional inductances. If you use another resistor, the reference resistor shall be connected as close to the “+OUT” and “-OUT” sockets of the CAR-PFS as possible.

Please note the the high power loss in case of the 1Ω resistor operated at 11 V according to the LV 124, the test setup should be prepared without power and **carried out only with the predefined verification procedure!** This procedure is located in the setup menu of the CAR-PFS80 generator.

Data Lines (2A):

This point applies to LV 124 (E13). The LV 124 requires reference measurements to prove the slew rate. For reference measurement, a 1Ω and a $1k\Omega$ ($\pm 5\%$) resistor (low inductance) are connected to the output.

A short cable connection must be established! A positive effect is also a twisting of the supply line.

Please note the the high power loss in case of the 1Ω resistor. **The maximum current of 2A must not be exceeded!**

The test setup should be prepared without power.

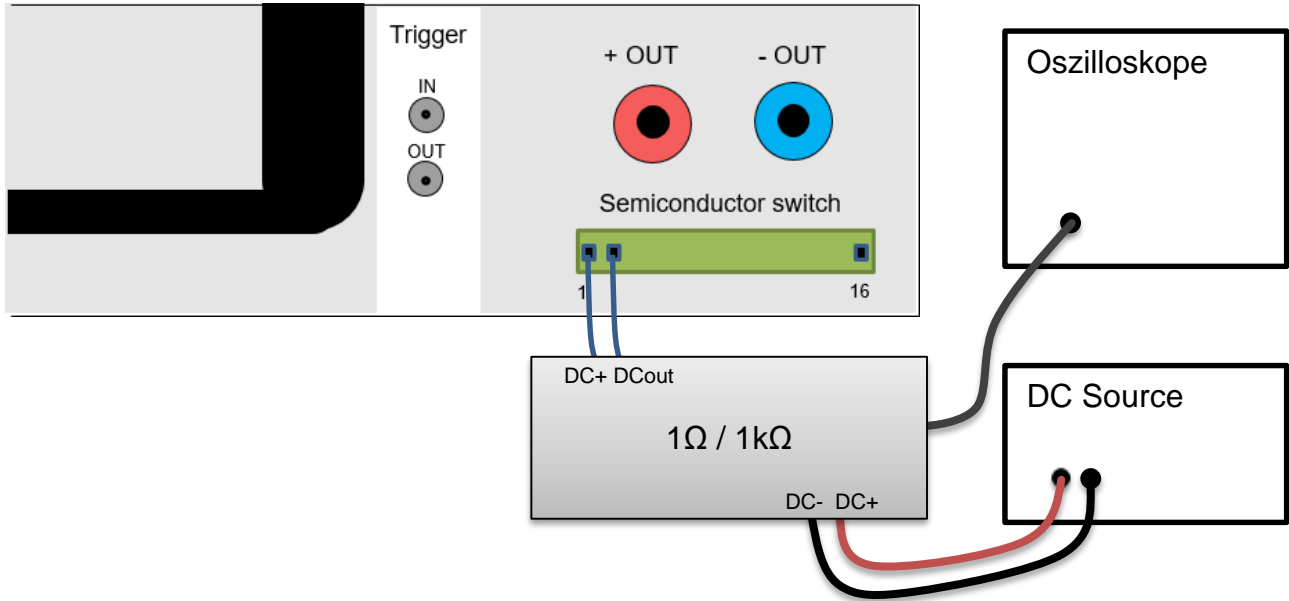

Technical specification	CAR-PFS-RCaI KIT
Power lines	
Type	1Ω
Max. Voltage	12V
Max. Power	30W, 150W 1s peak
Accuracy	1%
Type	100Ω
Max. Voltage	100V
Max. Power	30W, 100W 1s peak
Accuracy	1%
Data lines	
Type	1Ω
Max. Voltage	2V
Max. Power	1W, 4W 1s peak
Accuracy	1%
Type	1Ω
Max. Voltage	10V
Max. Power	1W, 4W 1s peak
Accuracy	1%
Including BNC and Adapter Cable	

Sales Partner:



ABSOLUTE EMC LLC.
Covering sales in North America
United States, Mexico, & Canada

absolute-emc.com
Phone: 703-774-7505
info@absolute-emc.com

Page 3 of 3
www.hilo-test.de