

TRANSIENT IMMUNITY TEST GENERATOR CAR-TG 20



According to

FORD FMC 1278	RI130, CI220
EMC-CE-2009.1	RI130, CI220, CI260

General:

The transient generator CAR-TG 20 is designed according strict specifications of Ford standards. As per standards FORD FMC1278 and EMC-CS-2009.1 the transient tests defined in RI130, CI220 and CI 260 are generated by CAR-TG20. By that is meant pulse forms: A1, A2-1, A2-2, C-1, C-2 and F. Therefore, a specified 12VAC Potter & Brumfield relay as well as other parts defined by standard create pulses which are close to real appearing transients.

Sales Partner:



ABSOLUTE EMC LLC.
Covering sales in North America
United States, Mexico, & Canada

absolute-emc.com
Phone:703-774-7505
info@absolute-emc.com

06/20
Page 1 of 3
www.hilo-test.de

Operation:

A microprocessor-controlled 7" touch screen display unit is integrated and permits an easy operation of the generator. Following Parameters can be selected and varied:

Parameter	Variations
Standard routine	RI130, CI220, CI260
Mode	M1, M2, M3
Pulse form	A1, A1-1, A1-2, C-1, C-2, F
Test time	1-1000s, infinity (Standard values predefined)
Operation	Start / Pause / Stop

Depending on parameters selected, the internal SW0-SW4 of standard are switched automatically, its state is also displayed in the screen. Modes M1 (rectangle) and M2, M3 (pseudo random rectangle) are generated internal.

The CAR-TG 20 offers a battery Input on the left. Outputs for the DUT for pulse A1, A1-1, A1-2, C-1 and F are located on the right side. As well a coaxial bridge can be set between Terminal Pulse C and Sink to define Test CI200 or RI130.

For maintenance reasons, the Potter & Brumfield relay is easy to reach and changeable. Therefore a test time counter on that device is available to detect the end of life of that component. A reset button of that timer is also present.

The CAR-TG 20 excels by its compact design, simple handling and precise reproducibility of test impulses.

Schematic:

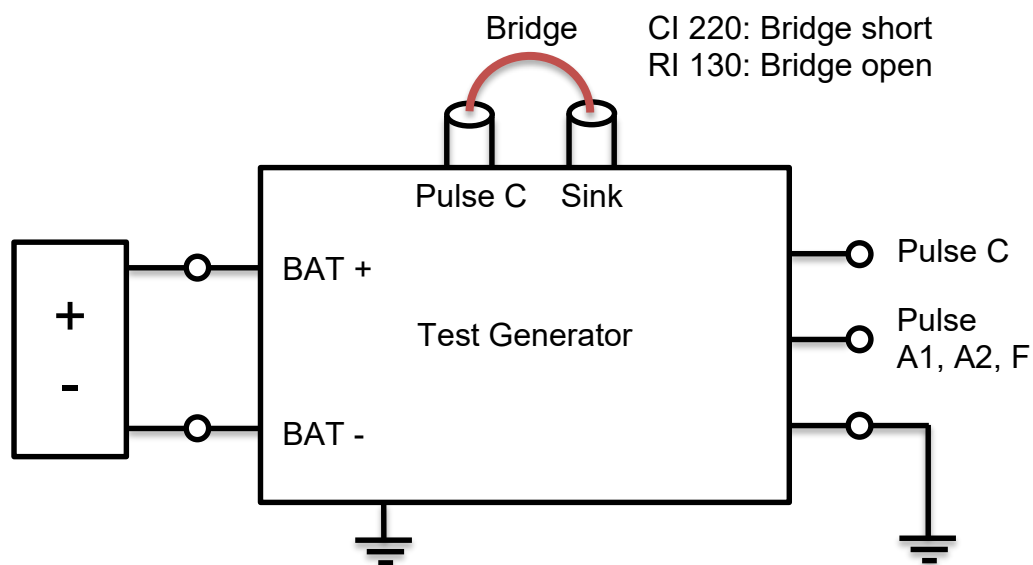

Technical specifications: CAR-TG 20

Mainframe

Microprocessor controlled touch panel	7", capacitive
Mains power / BAT-IN	9V – 56 VDC
Dimensions, case, W * H * D	330*115*230 mm ³
Weight	8kg

Technically:

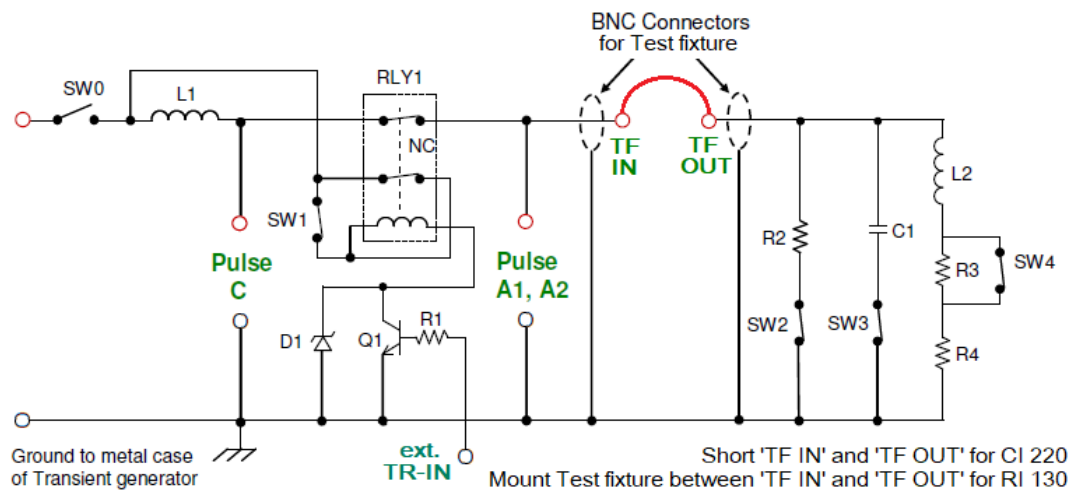

Resistor R1	51Ω, 0,25W
Resistor R2	220Ω, 2W
Resistor R3	33Ω, 10W
Resistor R4	6Ω, 50W
Capacitor C1	100nF PETP polyester film capacitor, 400V
Inductor L1	5 uH inductor (Osborne transformer #8745)
Inductor L2	100 mH inductor (Osborne transformer #32416)
Diode D1	Zener diode, 39V, 5W
Transistor Q1	NPN transistor
Switch SW0-SW4	Single Throw Switch
Relay RLY1	12 volt AC relay, NC contact used (Potter&Brumfield KUP-14A15-12)