

IPG 612T

RING-WAVE GENERATOR

Output voltage 0.2 – 6 kV

Frequency 100 kHz

Rise time 0.5µs



Picture: incl. Option PA 503

According to

IEC 61000-4-12	Ring wave test
IEC 1008-1	Ring wave test of RCCB's

High-voltage pulse generator producing Ring Wave 0.5 µs / 100 kHz acc. to IEC 61000-4-12. The output peak voltage can be preset continuously from 0.2 - 6 kV. Rise time 0.5µs to the first peak, ringing frequency 100 kHz.

A built-in voltage divider allows monitoring of the output voltage waveform.

The generator comprises an electronically regulated high-voltage power supply, an energy storage capacitor, a high-voltage/high-current switch, a pulse forming network and a control-and monitoring unit.

Moreover, the generator includes a Coupling-/Decoupling Network (CDN) for single-phase power supply lines. External coupling-/decoupling networks for 3-phase power supply lines are controlled by a built-in optical interface.

High-voltage pulses are generated synchronous with the mains power supply, phase shifting is digitally selectable.

Sales Partner:



ABSOLUTE EMC LLC.
Covering sales in North America
United States, Mexico, & Canada

absolute-emc.com
Phone: 703-774-7505
info@absolute-emc.com

08/17
Page 1 of 5
www.hilo-test.de

The generator excels by its compact design, simple handling and precise reproducibility of test impulses. It features a microprocessor controlled user interface and a 7" touch screen unit for ease of use. The microprocessor allows the user to execute either standard test routines or a "user defined" test sequence. A standard USB port provides the ability to print a summary of the test parameters to a USB stick.

The software program IPG-REMOTE allows full remote control of the test generator via Ethernet light guide as well as documentation and evaluation of test results, accordingly to the IEC 17025. To record definite impulses, it is equipped with an Impulse Recording Function (IRF) Moreover all generator functions may be computer controlled via the isolated optical interface.

Options	IPG 612T
Software IPG-REMOTE, for remote control	
With Impulse Recording Function (IRF)	
(XP, WIN7, WIN10) incl. 5m long light guide and PC Ethernet interface	
Modification for testing residual current operated circuit breakers (RCCB)	
Modification for testing residual current operated circuit breakers (RCCB) acc. to IEC 1008-1	
PROTECTIVE COVER ON THE EQUIPMENT TOP	
With safety interlock switch, connected to the safety interlock loop, red and green warning lamps installed acc. VDE 0104.	See figure
Typ PA 503, Dimensions W * H * D	400 * 140 * 300 mm ³
Typ PA 505, Dimensions W * H * D	400 * 250 * 400 mm ³

Accessories	IPG 612T
Coupling-/decoupling networks	
For 3-phase interference test acc. to IEC 61000-4-12	CDN 5416, CDN 2410

TECHNICAL SPECIFICATION	IPG 612T
Mainframe	
Microprocessor controlled touch panel	7", capacitive
Optical Ethernet Interface for remote control of the generator	Optional
Interface for saving reports	USB
External Trigger input/ output	Switch/ 10V
Connector for external safety interlock loop	24 V=
External red and green warning lamps	230V / 60 W
Mains power	90V – 264V / 50/60 Hz
Dimensions of desk top case W * H * D	450*180*500 mm ³
Weight	18kg
Generator section	
Impulse output voltage, adjustable	0.2 - 6.0 kV ± 10 %
Output wave form acc. to IEC 61000-4-12	0.5 μs /100 kHz
Oscillation frequency	100 kHz ± 10%
Voltage rise time to the first peak (open)	0.5 μs ± 30%
Current rise time to the first peak (short)	≤ 1 μs
Decaying voltage	0,4 < Ratio of <i>Pk2</i> to <i>Pk1</i> < 1,1 0,4 < Ratio of <i>Pk3</i> to <i>Pk2</i> < 0,8 0,4 < Ratio of <i>Pk4</i> to <i>Pk3</i> < 0,8
Polarity of output voltage	+/-, selectable
Maximum stored energy	10 Ws
Repetition rate, max.	60 transients per minute
High-voltage output HV-OUT, impedance selectable:	
PFN 1: Series resistor / max. short circuit output current 5kV	10 + 2 Ω / 416A
PFN 2: Series resistor / max. short circuit output current 5kV	10 + 20 Ω / 166A
COM: male connector, potential free	250 V/50 Hz, 1000 Vpeak
Impulse voltage divider integrated	ratio = 1000:1 ± 5%
Triggering : a) manual	key
b) ext. trigger input	switch
c) internal, automatic	test procedure
Mains synchronous trig.: Phase shifting, digitally selectable	0 - 360 ° ±5°
Coupling-/decoupling network for power supply lines, built-in	L1, N, PE
rated voltage, rated current	250 V, 16 A ≈ / 10 A =
Coupling mode, selectable: "Line to Line" and "Line to Ground"	Cc = 10 μF

Option 2: Ring Wave Test of RCCB's acc. to IEC 1008-1

The Ring-Wave Generator IPG 612T can be used for testing Residual Current operated Circuit Breakers (RCCB's) according to IEC 1008.

During this test, each current path of the RCCB is loaded with a ring wave current. Up to peak current values of 250 A the RCCB may not be triggered.

OPTION 2 includes the modification of the generator and an additional current viewing resistor for monitoring the output current.

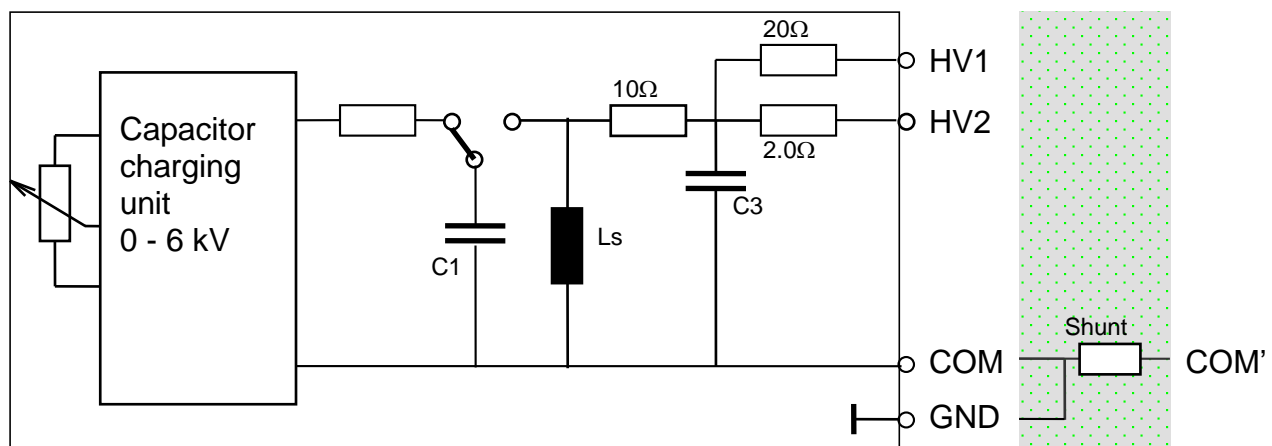

Figure 1: Ring-Wave Generator IPG 612T, schematic

The Ring-Wave Generator IPG 612T can be modified for testing Residual Current operated Circuit Breakers (RCCB's) according to IEC 1008 as follows:

1. The terminal COM is short circuited to terminal GND.
2. In order to monitor the output current a current viewing resistor $R_m = 2 \text{ m}\Omega$ is connected in series to the COM-terminal.

Modifications 1 and 2 are accomplished by connecting the specially designed SHUNT to the output terminals.

Protective earth terminals of the RCCB must be connected to the terminal COM'.

Additional accessories see Options

Option 3: Ring Wave Test of RCCB's acc. to IEC 1008-1 including safety test cover PA 503

The Ring-Wave Generator IPG 612T can be used for testing Residual Current operated Circuit Breakers (RCCB's) according to IEC 1008. During this test, each current path of the RCCB is loaded with a ring wave current. Up to peak current values of 250 A, the RCCB may not be triggered.

OPTION 2 includes the modification of the generator and an additional current viewing resistor for monitoring the output current.

In order to avoid human contact to the live parts of the output terminals and to provide for high level personal safety of the operator during impulse testing of RCCB's, the use of the safety test cover PA 503 is strongly recommended, see IEC 1008-1, Amend.1.

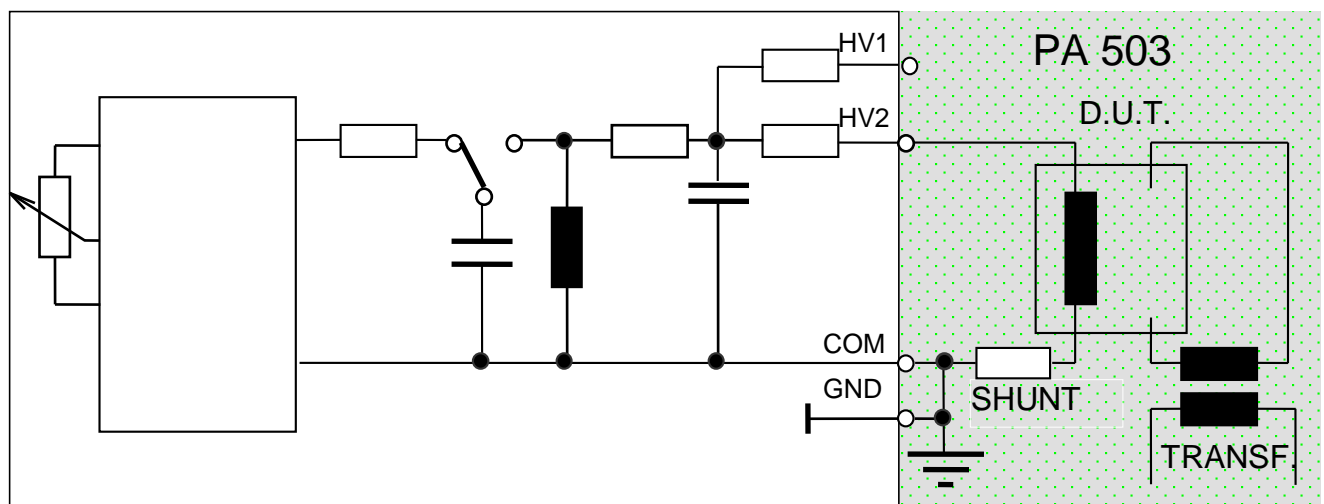

Figure 2: Ring-Wave Generators IPG 612T, schematic, +Safety test cover PA 503, incl. modification of IPG 612T for testing RCCB's acc. to IEC 1008-1.

1. The COM terminal is connected to GND.
2. In order to monitor the output current a current viewing resistor $R_m = 2 \text{ m}\Omega$ is connected between the test object and the COM/GND-terminal.
3. The high-voltage outputs HV-1 and HV-2 are connected to the safety test cover.
4. The safety test cover includes an isolating transformer with EMI-filter to supply the test object
5. The limit switch of the safety test cover is connected to the safety interlock loop of the generator. Upon opening the safety test cover, the generator is shut down.